

NAME	
DATE	
TRACK	
EVENT	

PINION	TRANSMISSION	SPUR
<input type="checkbox"/> 15T <input type="checkbox"/> 16T <input type="checkbox"/> 17T	<input type="checkbox"/> 1ST <input type="checkbox"/> 58T <input type="checkbox"/> 59T	
<input type="checkbox"/> 20T <input type="checkbox"/> 21T <input type="checkbox"/> 22T	<input type="checkbox"/> 2ND <input type="checkbox"/> 53T <input type="checkbox"/> 54T	

SIDE PULLEY	
<input type="checkbox"/> 25T(STD)	<input type="checkbox"/> 26T(OPT)

FRONT	SHOCKS	REAR
<input type="checkbox"/> USP2 <input type="checkbox"/> SHORT <input type="checkbox"/> STD	TYPE	<input type="checkbox"/> USP2 <input type="checkbox"/> SHORT <input type="checkbox"/> STD

SPRINGS	
#	OIL
<input type="checkbox"/> STD <input type="checkbox"/> OPTION	<input type="checkbox"/> STD <input type="checkbox"/> OPTION

O RING		PISTONS	
<input type="checkbox"/> 1-1.3 Hole	<input type="checkbox"/> 2-1.1 Hole	<input type="checkbox"/> 1-1.3 Hole	<input type="checkbox"/> 2-1.1 Hole
<input type="checkbox"/> 3-0.9 Hole		<input type="checkbox"/> 3-0.9 Hole	

FRONT	DIFF	REAR
<input type="checkbox"/> UP <input type="checkbox"/> STD	<input type="checkbox"/> DIFF <input type="checkbox"/> G228 <input type="checkbox"/> ADJUSTABLE	<input type="checkbox"/> UP <input type="checkbox"/> STD

FRONT	ANTI-ROLL BAR	REAR
	mm	mm

FRONT	RIDE HEIGHT	REAR
	mm	mm

FRONT	WIDTH	REAR
	mm	mm

TIRES		CONTROLLED
BRAND		<input type="checkbox"/> YES <input type="checkbox"/> NO

LEFT	FRONT	RIGHT	LEFT	REAR	RIGHT
mm	mm	mm	mm	mm	mm

FRONT	WHEEL PLATE	REAR
<input type="checkbox"/> YES <input type="checkbox"/> NO	WHEEL PLATE	<input type="checkbox"/> YES <input type="checkbox"/> NO

HEX HUB	U (Universal) / D (Drive Shaft)	
<input type="checkbox"/> STD <input type="checkbox"/> OPT <input type="checkbox"/> OPT (LARGE)	FRONT	REAR
	<input type="checkbox"/> 90° U(OPT) <input type="checkbox"/> 0° U(STD) <input type="checkbox"/> 0°U(50mm)	<input type="checkbox"/> 90° U(OPT) <input type="checkbox"/> 0° U(STD) <input type="checkbox"/> 0°U(50mm)

FRONT	WHEEL SHAFT	REAR	BODY
<input type="checkbox"/> STD <input type="checkbox"/> LIGHT	<input type="checkbox"/> STD <input type="checkbox"/> LIGHT		TYPE POSITION WING

<input type="checkbox"/> STD	<input type="checkbox"/> CARBON
------------------------------	---------------------------------

BUMPER HOLE	
A	B
C	D

FRONT	CENTER	REAR
7 6 5 4 3 2 1	7 6 5 4 3 2 1 NO	7 6 5 4 3 2 1

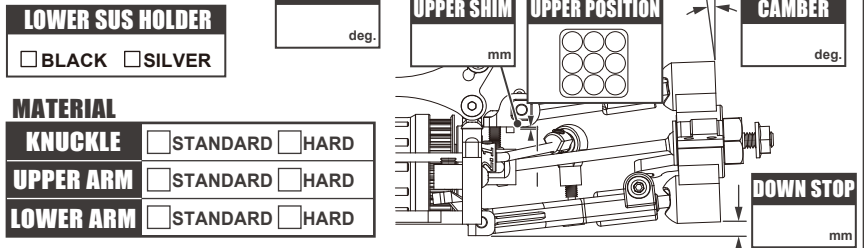
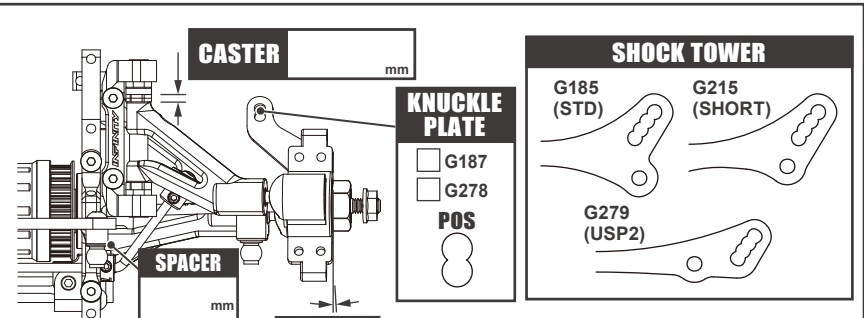

MATERIAL	<input type="checkbox"/> STANDARD <input type="checkbox"/> HARD
KNUCKLE	<input type="checkbox"/> STANDARD <input type="checkbox"/> HARD
UPPER ARM	<input type="checkbox"/> STANDARD <input type="checkbox"/> HARD
LOWER ARM	<input type="checkbox"/> STANDARD <input type="checkbox"/> HARD

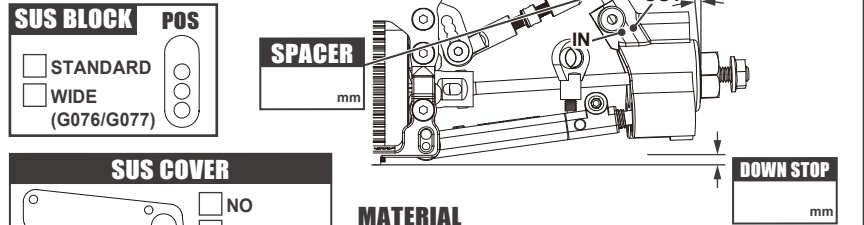
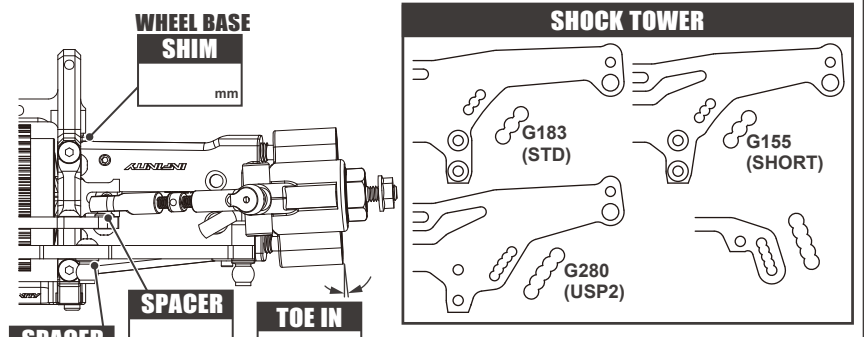

SUS COVER	<input type="checkbox"/> NO <input type="checkbox"/> STANDARD <input type="checkbox"/> HARD <input type="checkbox"/> CARBON
MATERIAL	<input type="checkbox"/> STANDARD <input type="checkbox"/> HARD
SUS ARM	<input type="checkbox"/> STANDARD <input type="checkbox"/> HARD
REAR HUB	<input type="checkbox"/> STANDARD <input type="checkbox"/> HARD

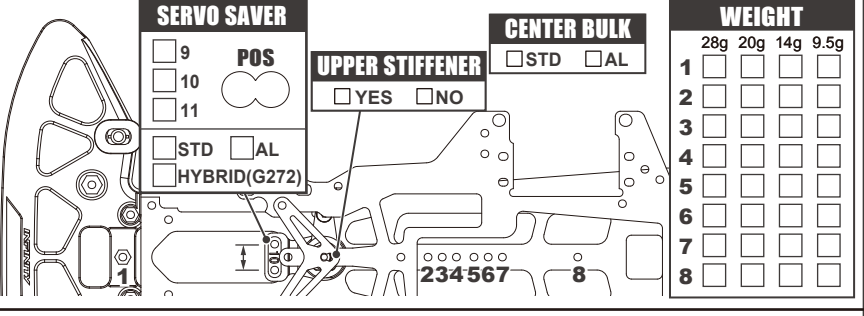

CENTER STIFFENER	<input type="checkbox"/> YES <input type="checkbox"/> NO
REAR CHASSIS STIFFENER	<input type="checkbox"/> YES <input type="checkbox"/> NO

COMMENT